

ASSEMBLY INSTRUCTION

MODEL : CF 5017
3 SEATER

A	Back Rest	1 pc
B	Arm	2 pcs
C	Sitter	2 pcs
D	Side Rail	1 pc
E	Legs 138 x 138 x 138/60	4 pcs
F	Slat 498mm	12 pcs
G	End Holder	24 pcs
H	M5 x 70 mm	1 pc
I	M4 x 65 mm	1 pc
J	JCBC M6 X 30	8 pcs
K	Flat Washers	8 pcs
L	JCBB N8 X 40	4 pcs
M	CSK Screw 32mm	2 pcs
N	Small Adjuster	1 pc
O	JCBC M6 x 40	1 pc
P	Support Legs 240mm	1 pc
Q	Slat 498mm	1 pc

Step 1 : Attach the arm (B) to the back rest (A) by pushing the bracket down to fit it.

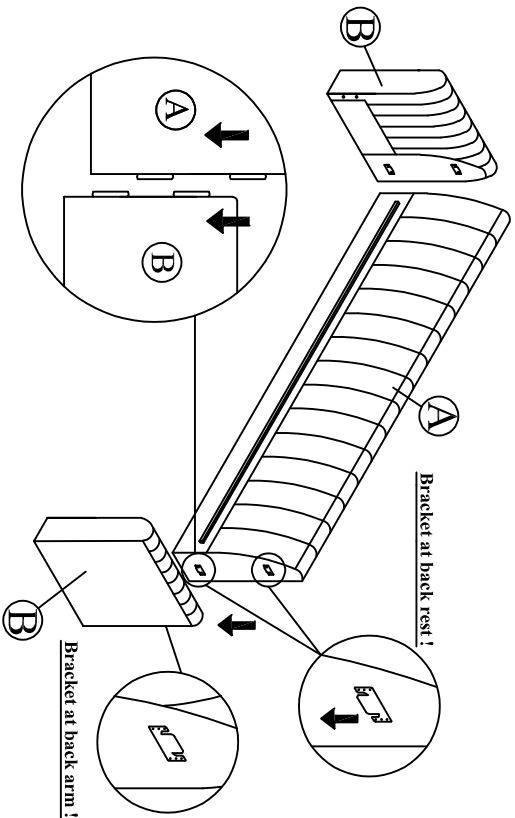

Step 2 : Attach the side rail (D) to the arm (B).

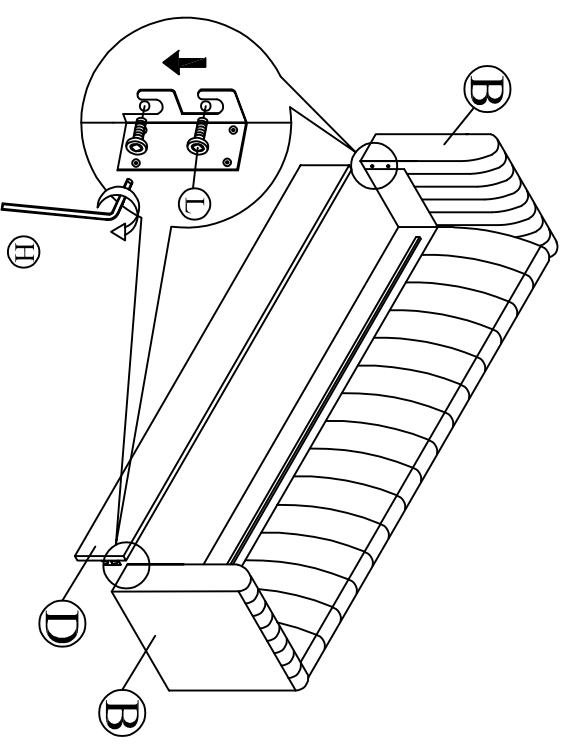

Step 3 : Install the legs (E) to back rest (A) and arm (B).

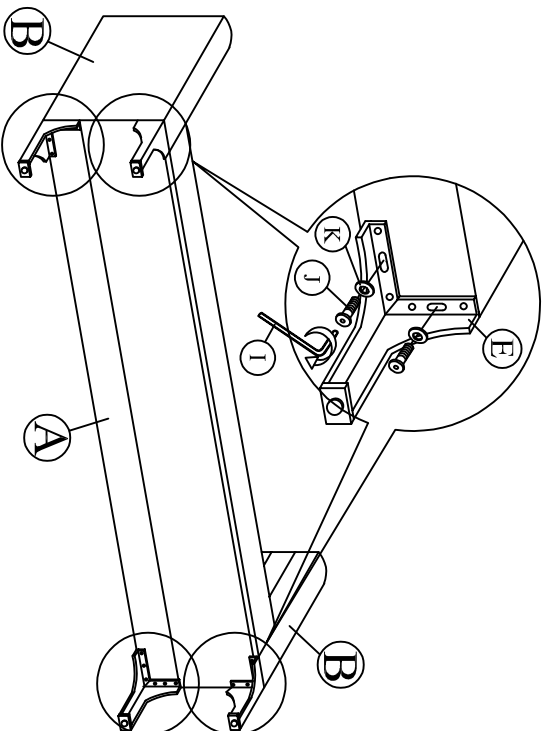

Step 4 : Attach the support legs (P) to the slat (Q) of the sofa as shown.

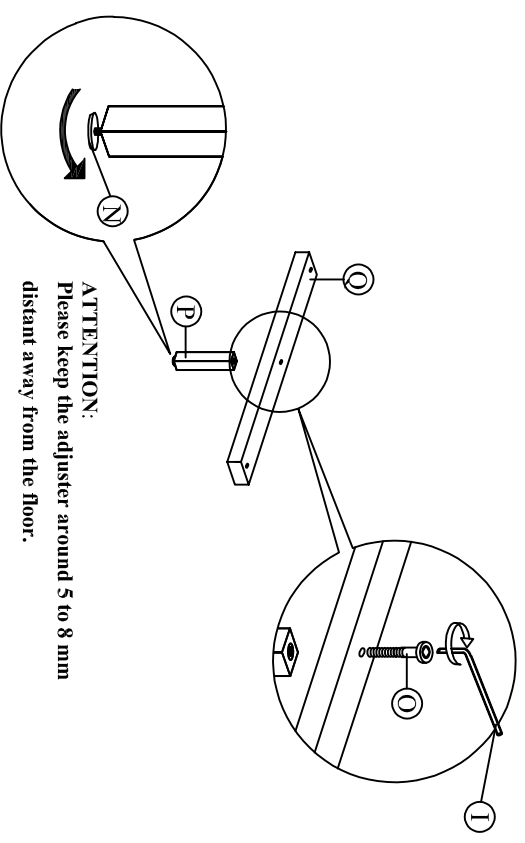

Step 5 : Attach the slat (Q) and support legs (P) to the center of back rest (A) and side rail (D).

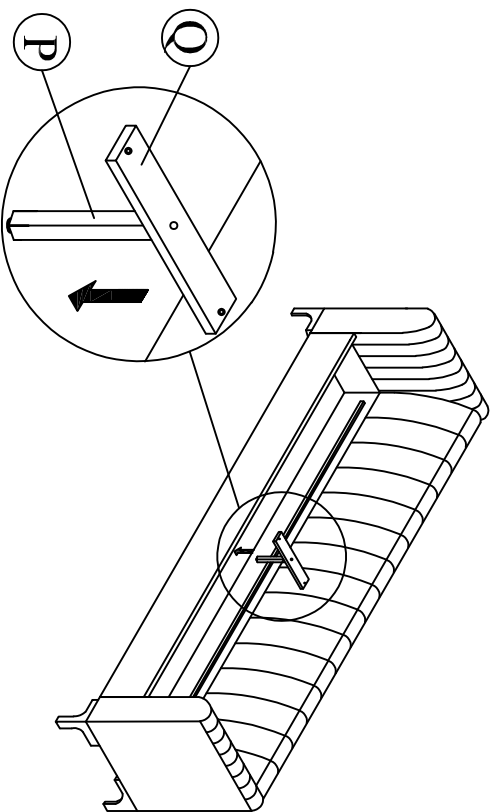

Step 6: Attach the slat (Q) to the back rest (A) and side rail (D).

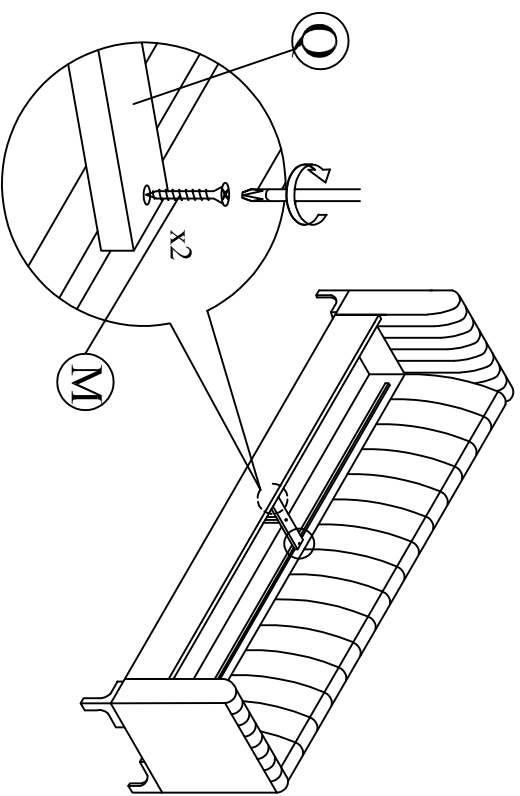

Step 7 : Assembly of the slat holders with LVL slats as shown. Attach the sitter (C) to the arm (B), side rail (D) and back rest (A).

